

Linear Unit RHL110

Dimensions in mm.

RHL is a complete linear unit with rail guide and toothed belt. The unit is delivered ready to mount and thereby saves both design and assembly time.

Linear Unit RHL is available in two sizes, RHL80 and RHL110. The units are based on aluminium profile and equipped with linear rail, belt and pulleys. The stroke length is selectable per millimetre from 0 up to 10 metres.

Rollco cut and assemble everything in our own workshop, which enables very short delivery times.

There are various accessories such as T-slots, angles and mounting plates in stock. We can also manufacture motor flanges and make other adjustments according to customer specifications.

Product characteristics:

- Compact unit
- Compatible with structural systems
- Possible to use in X-Y-Z systems
- Customized versions available upon request

For higher values than stated below, please contact Rollco. The No load torque is a typical value for a new unit and will normally decrease with use. For extremely long strokes (above 6 meter) and for units oriented horizontal and with the slider oriented to the side, the no load torque value may exceed the typical values stated.

Max. Speed (m/s): 2.5

Max. Drive Torque (Nm): 75

Pulley radius: 36.6

Belt Type: AT 10

Belt Width: 49

Tooth pitch: 10

Max. Traction Load Fx (N): 2000

Belt Breaking Strength (N): 29780

Stroke for shaft revolution: 230

No Load Torque (Nm): 2

Add. Mass of Complete Unit for Each +100 mm Stroke (kg): 1.34





General Data

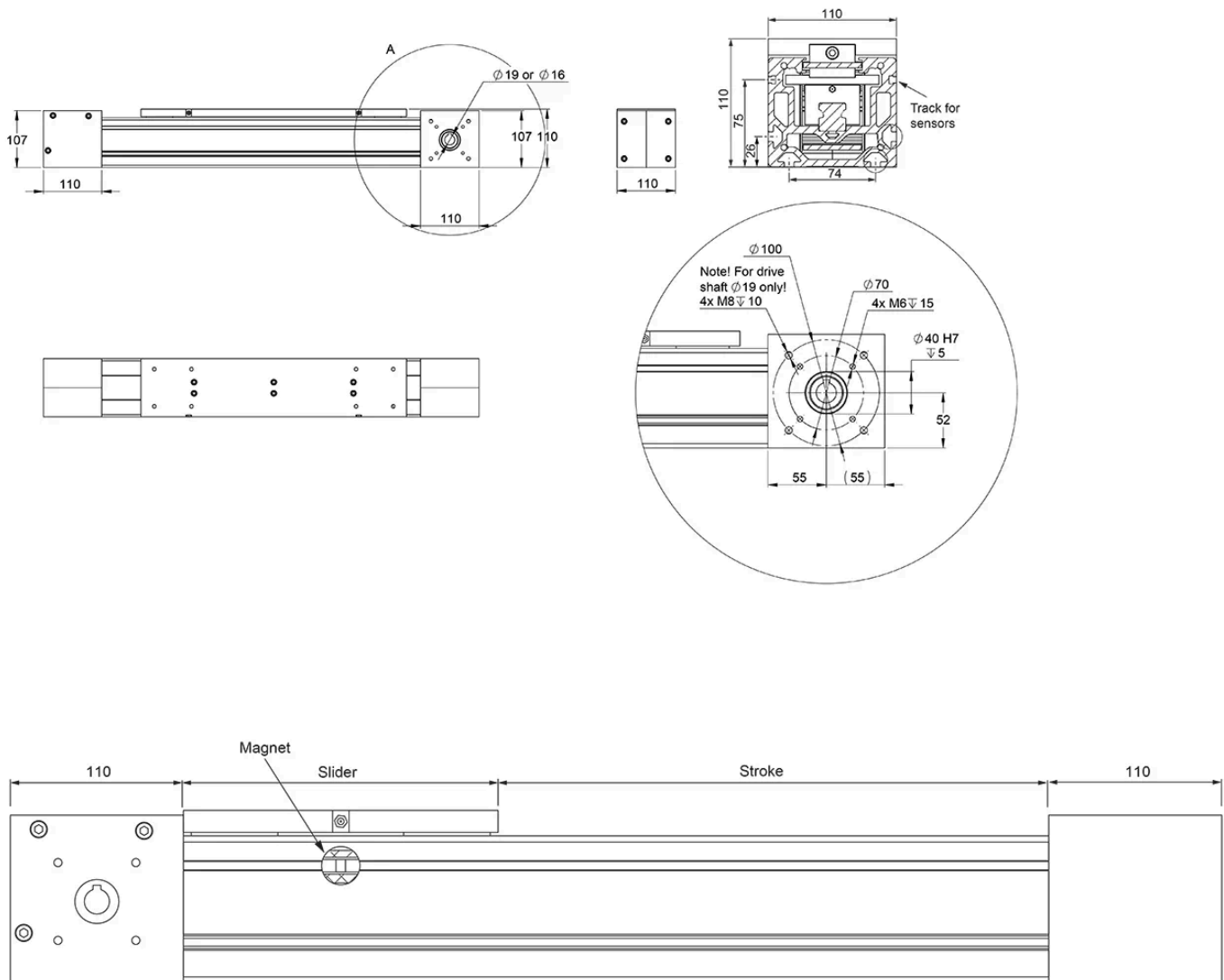

Total length = Stroke + slider + 220
 Stroke: We recommend to add min. 50 mm to the nominal stroke (stroke = nominal stroke + 50 mm)

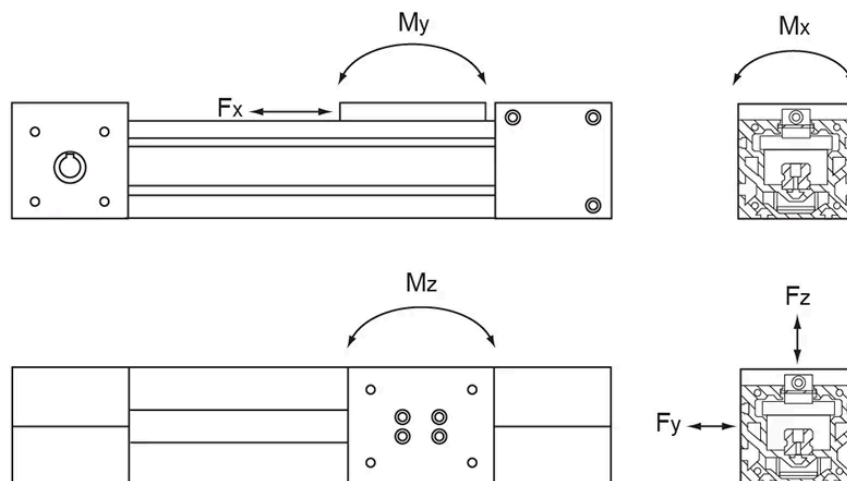
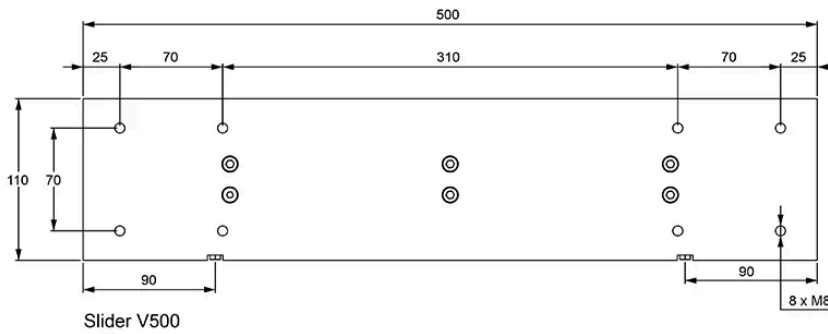
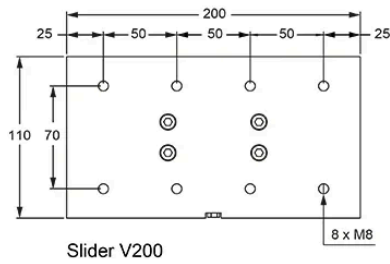

Designation	Slider length	Mass of Linear Unit incl. Slider - 0 mm Stroke (kg)	Mass of Slider (kg)	Permissible Load Fz (N)	Permissible Load Fy (N)
RHL110-V200	200	14.5	1.8	2000	1000
RHL110-V500	500	20.4	3.8	4000	2000

Designation	Permissible Moment Mx (Nm)	Permissible Moment My (Nm)	Permissible Moment Mz (Nm)
RHL110-V200	100	100	100
RHL110-V500	200	900	900