

Miniature Metal Bellows Coupling MKM

- Standard series with lateral clamping hub
- High torsional stiffness - flexible

Tightening torque refers to screws.

Dimensions in mm. Length dimensions according to DIN ISO 2768 cH.

Material: Bellows: stainless steel Hubs: high-tensile strength aluminium Clamping screws: ISO 4762 - 12.9 Press-fit wire: brass

Temperature range (°C): -40° to +200°C

Max. Speed (rpm): 20 000



General Data

Designation	Nominal Torque (Nm)	Max. Torque (Nm)	Moment of inertia ($10^{-6}\text{kg}\cdot\text{m}^2$)	Torsional stiffness (Nm/arcmin)	Axial max. shaft misalignment (mm)
MKM0.4	0.4	0.8	0.3	50	0.35
MKM0.9	0.9	1.8	0.4	90	0.3
MKM2	2	4	3.0	230	0.5
MKM4	4	8	3.0	4 560	0.4
MKM7	7	14	14	1 100	0.6
MKM8	8	16	26	1 350	0.8
MKM12	12	24	30	2 050	0.7

Designation	Lateral max. shaft misalignment (mm)	Axial spring rate (N/mm)	Lateral spring rate (N/mm)	Tightening Torque (Nm)	Weight (g)
MKM0.4	0.2	10	15	1	10
MKM0.9	0.2	21	26	1	12
MKM2	0.2	15	15	2	30
MKM4	0.2	35	65	2	40
MKM7	0.25	45	60	4	80
MKM8	0.3	16	24	8	130
MKM12	0.25	40	70	8	125

Dimensions

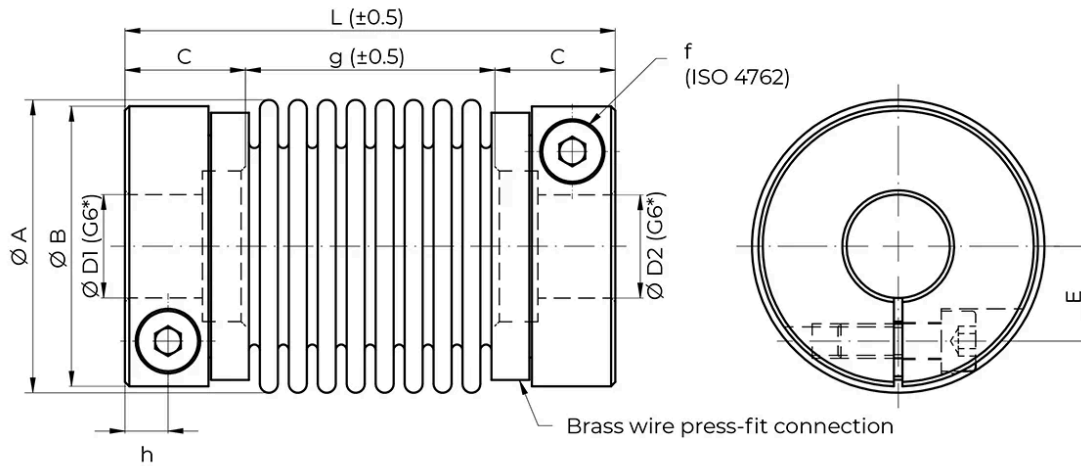

*Other bore tolerances on request.

Designation	Nominal Torque (Nm)	A	B	L	C	g	f	E	$\varnothing D1/2$ min.
MKM0.4	0.4	16.5	-	30	9	12	M2.5	4.6	3
MKM0.9	0.9	16.5	-	31.5	9	13.5	M2.5	4.6	3
MKM2	2	24.5	-	42	13	16	M3	7.5	3
MKM4	4	24.5	-	44	13	18	M3	7.5	5
MKM7	7	34 \pm 0.5	32.5	57	14	29	M4	11	6
MKM8	8	39.5	-	60	16.6	26.5	M5	13	6
MKM12	12	39.5	-	62	16.6	29	M5	13	6

Designation	$\varnothing D1/2$ max.
MKM0.4	6.35
MKM0.9	6.35
MKM2	10
MKM4	10
MKM7	17
MKM8	19
MKM12	19