

MGBS

The MGBS is a ball screw driven mini linear unit where the rotary motion (rotation) of the drive shaft is converted to the linear motion (translation) of the carriage with high mechanical efficiency and low internal friction.

High-performance features such as high speed, good positioning accuracy, and high repeatability are ensured through a precision ball screw drive and a linear guiding system.

A preassembled standard motor (in-line with a motor adapter and a coupling or in-parallel with a motor side drive and a timing belt) together with a standard drive, makes the system plug and drive ready. Compact dimensions and optimally selected motor combinations cover a wide range of applications.

Options, such as different ball screw leads, together with a wide range of accessories and possible multi-axis system combinations make this product highly flexible.

□ = Square cross section

Dimensions in mm.

For other CAD files, please contact Rollco.

Ambient Temperature (°C): 0 °C ~ +50 °C

Ambient Temperature without a Motor (°C): 0 °C ~ +60 °C

Protection Class: IP40

Duty Cycle: 100 %

Maintenance: Life-time pre-lubricated

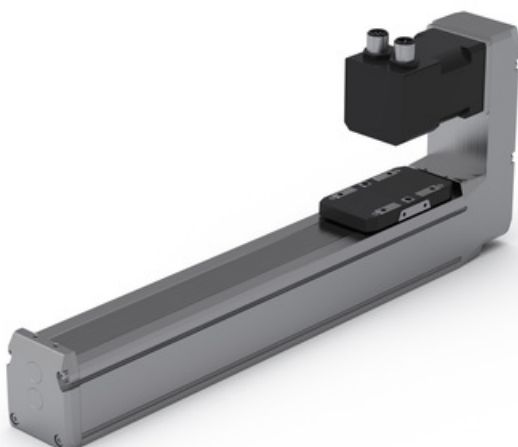

MGBS

MGBS with motor and motor adapter VK

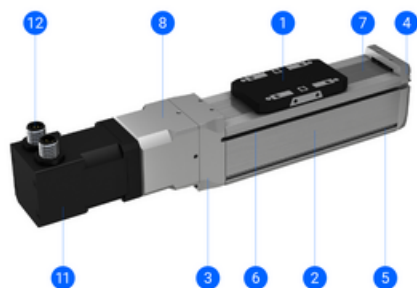

1. Carriage
2. Aluminium profile
3. Drive block
4. End block
5. Mounting slots
6. Slot for the magnetic field sensors
7. Corrosion-resistance protection strip
8. Motor adapter VK with a coupling
11. Preassembled motor (with/without a brake)
12. Standard connectors (motor, encoder and brake - optionally)

MGBS with motor and motor side drive MSD



9. Motor side drive MSD with a timing belt
11. Preassembled motor (with/without a brake)
12. Standard connectors (motor, encoder and brake - optionally)

MGBS without motor

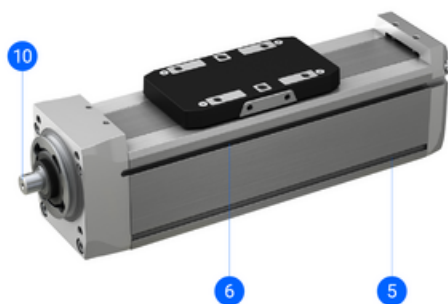

5. Mounting slots
6. Slot for the magnetic field sensors
10. Drive shaft of the precision ball screw drive

General Data

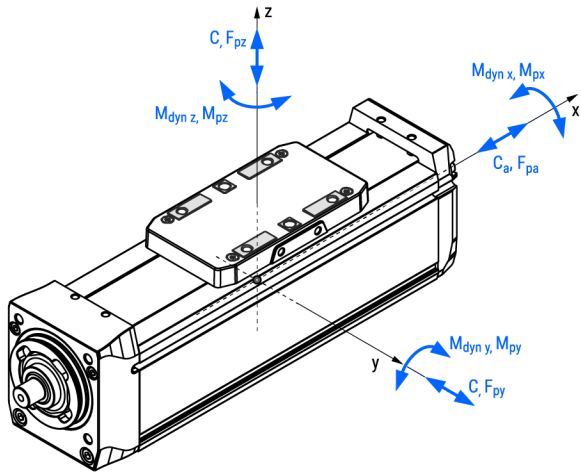

The moved mass is already considered in the equation for calculating the mass of the linear unit m_{MGBS} and the mass moment of inertia J_{MGBS} . The moved mass includes the mass of the carriage together with the ball nut.

For the combination with a standard motor and motor adapter VK or motor side drive MSD the mass m_{MGBS} should be increased by $m_{\text{VK+m}}$ or $m_{\text{MSD+m}}$ respectively.

Abs. stroke	Absolute stroke [mm]
m_{load}	Applied mass to be moved [kg]

Designation	Description	Ball Screw (d x l)	Axial Dynamic Load Capacity C_a (N)	Dynamic Load Capacity C (N)	Dynamic Moment M_x (Nm)
MGBS 32 - 8x2	Without a motor	8 x 2	2000	1310	4.8
MGBS 32 - 8x8	Without a motor	8 x 8	1500	1310	4.8
MGBS 45 - 10x3	Without a motor	10 x 3	3500	3240	20.1
MGBS 45 - 10x10	Without a motor	10 x 10	3200	3240	20.1
MGBS 60 - 12x5	Without a motor	12 x 5	5000	11190	77.4
MGBS 60 - 12x10	Without a motor	12 x 10	3800	11190	77.4

Designation	Dynamic Moment M_y (Nm)	Dynamic Moment M_z (Nm)	Max. Permissible Loads Forces F_{py} (N)	Max. Permissible Loads Forces F_{pz} (N)	Max. Permissible Loads Moments M_{px} (Nm)	Max. Permissible Loads Moments M_{py} (Nm)
MGBS 32 - 8x2	4.1	4.1	200	300	2.0	1.8
MGBS 32 - 8x8	4.1	4.1	200	300	2.0	1.8
MGBS 45 - 10x3	17.4	17.4	400	700	7.4	6.3
MGBS 45 - 10x10	17.4	17.4	400	700	7.4	6.3
MGBS 60 - 12x5	79.8	79.8	850	2000	29.2	30.8
MGBS 60 - 12x10	79.8	79.8	850	2000	29.2	30.8

Designation	Max. Permissible Loads Moments Mpz (Nm)	Axial Backlash (mm)	Max. Repeatability (mm)	Absolute Stroke	Max. Permissible Axial Load Fpa (N)	Max. Permissible Payload Horizontal mph (kg)
MGBS 32 - 8×2	1.3	≤ 0.06	± 0.015	50, 100, 150, 200, 250, 300, 400, 500, 600, 700, 800	285	31
MGBS 32 - 8×8	1.3	≤ 0.06	± 0.015	50, 100, 150, 200, 250, 300, 400, 500, 600, 700, 800	285	31
MGBS 45 - 10×3	4.7	≤ 0.06	± 0.015	50, 100, 150, 200, 250, 300, 400, 500, 600, 700, 800	695	71
MGBS 45 - 10×10	4.7	≤ 0.06	± 0.015	50, 100, 150, 200, 250, 300, 400, 500, 600, 700, 800	695	71

General Data

Designation	Max. Permissible Loads Moments Mpz (Nm)	Axial Backlash (mm)	Max. Repeatability (mm)	Absolute Stroke	Max. Permissible Axial Load Fpa (N)	Max. Permissible Payload Horizontal mph (kg)
MGBS 60 - 12×5	31.8	≤ 0.06	± 0.010	50, 100, 150, 200, 250, 300, 400, 500, 600, 700, 800, 900, 1000	1100	204
MGBS 60 - 12×10	31.8	≤ 0.06	± 0.010	50, 100, 150, 200, 250, 300, 400, 500, 600, 700, 800, 900, 1000	1100	204

Designation	Max. Permissible Payload Vertical mpv (kg)	Max. Drive Torque Mp (Nm)	No Load Torque Mo (Nm)	Max. Permissible Radial Load on Shaft Fpr (N)	Max. Travel Speed Vmax (m/s)	Max. Rotational Speed (rev/min)
MGBS 32 - 8×2	24	0.10	0.04	50	0.150	4500
MGBS 32 - 8×8	24	0.40	0.05	50	0.600	4500
MGBS 45 - 10×3	59	0.37	0.10	100	0.225	4500
MGBS 45 - 10×10	59	1.23	0.11	100	0.750	4500
MGBS 60 - 12×5	93	0.97	0.16	200	0.483	5800
MGBS 60 - 12×10	93	1.95	0.17	200	0.967	5800

Designation	Max. Acceleration (m/s ²)	Moved Mass (kg)	Mass of Linear Unit (kg)	Mass Moment of Inertia JMGBS (10 ⁻² kg cm ²)	Planar Moment of Inertia Iy (cm ⁴)	Planar Moment of Inertia Iz (cm ⁴)
MGBS 32 - 8×2	20	0.12	0.36 + 0.0015 × Abs. Stroke	0.85 + 0.0024 × Abs. Stroke + 0.1013 × mload	4.3	4.6
MGBS 32 - 8×8	20	0.12	0.36 + 0.0015 × Abs. Stroke	1.04 + 0.0025 × Abs. Stroke + 1.6211 × mload	4.3	4.6
MGBS 45 - 10×3	20	0.23	0.80 + 0.0028 × Abs. Stroke	3.17 + 0.0055 × Abs. Stroke + 0.2280 × mload	14.3	15.9
MGBS 45 - 10×10	20	0.23	0.80 + 0.0028 × Abs. Stroke	3.72 + 0.0056 × Abs. Stroke + 2.5330 × mload	14.3	15.9
MGBS 60 - 12×5	20	0.53	1.80 + 0.0049 × Abs. Stroke	11.04 + 0.0132 × Abs. Stroke + 0.6333 × mload	43.8	50.3
MGBS 60 - 12×10	20	0.53	1.80 + 0.0049 × Abs. Stroke	11.97 + 0.0126 × Abs. Stroke + 2.5330 × mload	43.8	50.3

Dimensions

MGBS without motor

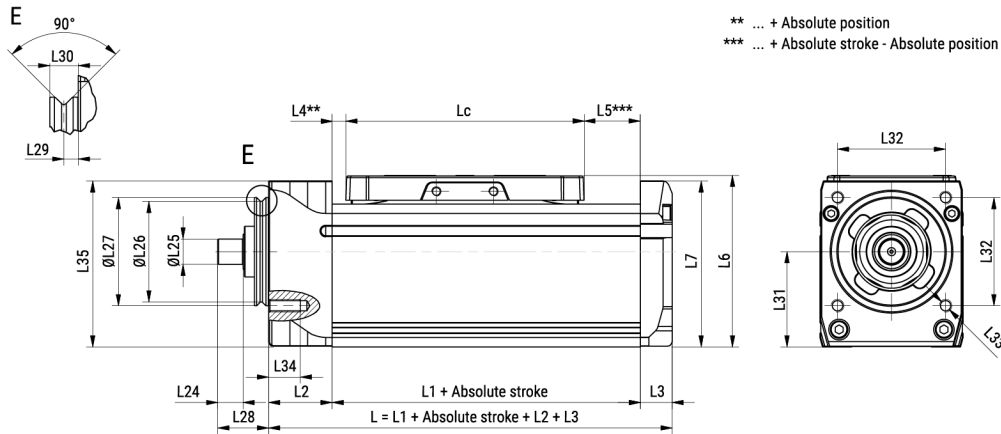

Absolute stroke of the MGBS definition

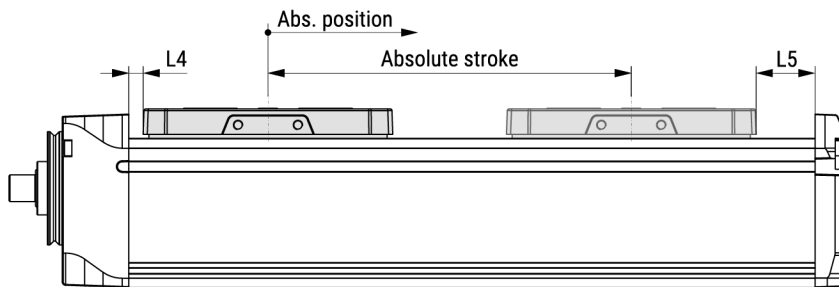

Designation	Lc	L1	L2	L3	L4	L5	L6	L7	L8
MGBS 32 - 8×2	65	81.5	16	8	2.5	14	38.5	35.75	32
MGBS 32 - 8×8	65	81.5	16	8	2.5	14	38.5	35.75	32
MGBS 45 - 10×3	75	97	20	10	4.3	17.7	54	52.25	45
MGBS 45 - 10×10	75	97	20	10	4.3	17.7	54	52.25	45
MGBS 60 - 12×5	90	133	24	12	3.2	39.8	72	68.75	60
MGBS 60 - 12×10	90	133	24	12	3.2	39.8	72	68.75	60

Designation	L9	L10	L11	L12	L13	L14	L15	L16	L17	L18
MGBS 32 - 8×2	4.4	23.7	4	5.9	18	M2	4	14.6	18.4	22.5
MGBS 32 - 8×8	4.4	23.7	4	5.9	18	M2	4	14.6	18.4	22.5
MGBS 45 - 10×3	4.4	36.5	5	7.8	18	M3	6	18.6	26.4	32
MGBS 45 - 10×10	4.4	36.5	5	7.8	18	M3	6	18.6	26.4	32
MGBS 60 - 12×5	4.4	45	6	11	30	M4	6	25.4	38.4	45
MGBS 60 - 12×10	4.4	45	6	11	30	M4	6	25.4	38.4	45

Designation	L19	L20	L21	L22	L23	L24	L25	L26	L27	L28
MGBS 32 - 8×2	30	35	M3	2 (H7)	5	7	5 (h7)	22.6	25 (h7)	14
MGBS 32 - 8×8	30	35	M3	2 (H7)	5	7	5 (h7)	22.6	25 (h7)	14

Dimensions

Designation	L19	L20	L21	L22	L23	L24	L25	L26	L27	L28
MGBS 45 - 10×3	42	42	M4	4 (H7)	6	8	8 (h7)	31.6	34	16
MGBS 45 - 10×10	42	42	M4	4 (H7)	6	8	8 (h7)	31.6	34	16
MGBS 60 - 12×5	57	55	M5	5 (H7)	8	10	10 (h7)	39.6	42	20
MGBS 60 - 12×10	57	55	M5	5 (H7)	8	10	10 (h7)	39.6	42	20

Designation	L29	L30	L31	L32	L33	L34	L35
MGBS 32 - 8×2	2.3	4.5	20	24.5	M3	6	35.75
MGBS 32 - 8×8	2.3	4.5	20	24.5	M3	6	35.75
MGBS 45 - 10×3	2.3	4.5	30	34	M4	10	52.25
MGBS 45 - 10×10	2.3	4.5	30	34	M4	10	52.25
MGBS 60 - 12×5	2.3	4.5	39	48	M5	10	68.75
MGBS 60 - 12×10	2.3	4.5	39	48	M5	10	68.75